



POWER OPTO 創巨光科技股份有限公司

235 台北縣中和市建一路 186 號 B1 TEL: 886-2-8227-3239 FAX: 886-2-8227-9112

PO- TS6723LSN-049

DATA SHEET

QC:

ENG:

Prepared By:

**1. SPECIFICATIONS****Absolute Maximum Ratings**

(Ta=25°C)

Parameter	Symbol	MAX.	Unit
Continuous Forward Current	If	25	mA
Pulse Forward Current*	Ifp	100	mA
Reverse Voltage	Vr	5	V
Power Consumption	Pc	95	mW
Operating Temperature Range	Topr	-40 ~ +85	°C
Storage Temperature Range	Tstg	-40 ~ +100	°C
Electrostatic Discharge	ESD	150	V
Soldering Temperature	Tsld	Reflow Soldering:240°C/10sec Hand Soldering:350°C/3sec	

*Duty 1/10 @ 1KHZ

Electrical / Optical Characteristics

(Ta=25°C)

Parameter	Symbol	Min.	Typ.	Max.	Unit	Test Condition
Forward Voltage*	Vf	2.8	/	3.8	V	If=20mA
Luminous intensity*	Iv	1550	1700	/	mcd	If=20mA
Reverse Current	Ir	/	/	10	µA	Vr=5V
Viewing Angle	2θ _{1/2}	/	120	/	Deg	*

*Forward voltage measurement allowance is ±0.1V.

*Luminous intensity is measured with a light sensor and filter combination that approximates the CIE eye-response curve.

*Luminous Intensity Measurement Allowance is ± 10%.

*Dominant Wavelength measurement allowance is ±1nm.

*2θ_{1/2} is the off-axis angle at which the luminous intensity is half the axial luminous intensity.

*Please see attachments for BIN classifications.



Bin Code List:

Bin Range of Color

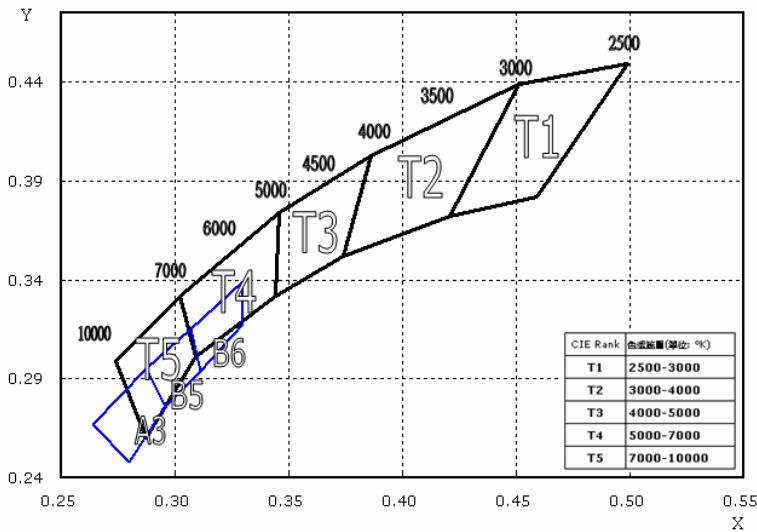

T1		T2		T3		T4		T5	
x	y	x	y	x	y	x	y	x	y
0.499	0.449	0.451	0.439	0.386	0.403	0.346	0.374	0.302	0.332
0.459	0.382	0.421	0.372	0.374	0.352	0.344	0.332	0.309	0.301
0.421	0.372	0.374	0.352	0.344	0.332	0.309	0.301	0.287	0.260
0.451	0.439	0.386	0.403	0.346	0.374	0.302	0.332	0.274	0.299

A3		B5		B6	
x	y	x	y	x	y
0.287	0.295	0.307	0.315	0.330	0.339
0.296	0.276	0.311	0.294	0.330	0.318
0.280	0.248	0.296	0.276	0.311	0.294
0.264	0.267	0.287	0.295	0.307	0.315

- * Condition: If = 20mA
- * C.I.E. 1931 chromaticity diagram
- * Color coordinates measurement allowance is ±0.01

Bin Range of Luminous Intensity

Condition : If=20mA		Unit : mcd	
Bin Code		Min	Max
P24	H13	1550	1700
	H14	1700	1900
	H15	1900	2100

Luminous Intensity Measurement Allowance is ± 10%.

Bin Range of Forward Voltage

Condition : If=20mA		Unit : v		
Bin Code		Min	Max	Bin Code
VH	G2	2.8	2.9	TG
	H1	2.9	3.0	
VI	H2	3.0	3.1	TH
	I1	3.1	3.2	
VJ	I2	3.2	3.3	TI
	J1	3.3	3.4	
VK	J2	3.4	3.5	TJ
	K1	3.5	3.6	
	K2	3.6	3.7	TK
	L1	3.7	3.8	

Forward voltage measurement allowance is ±0.1V.

Typical Electrical / Optical Characteristics Curves

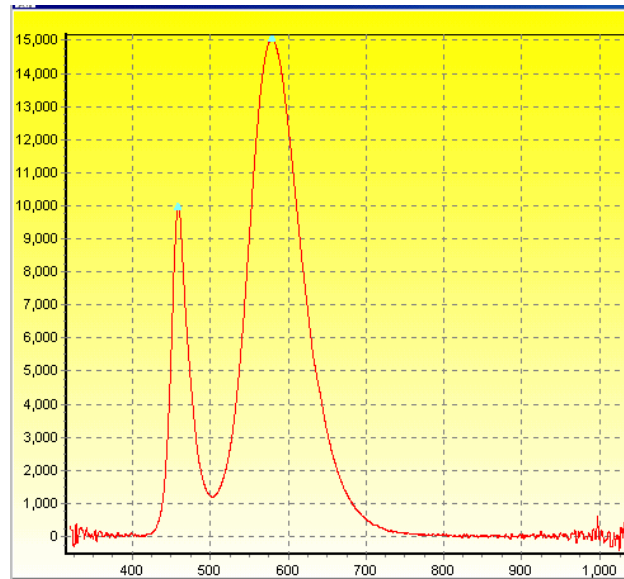

* CCT 3000° K

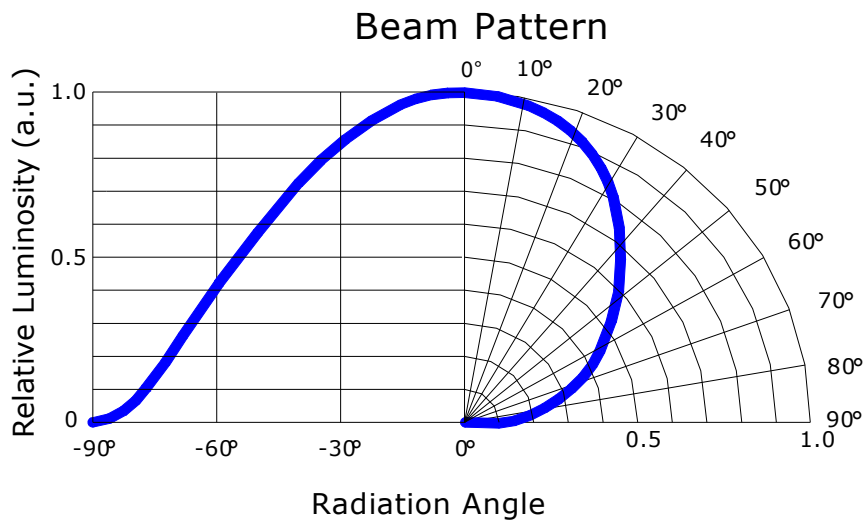

2. Package

Outline Dimension (unit= mm)

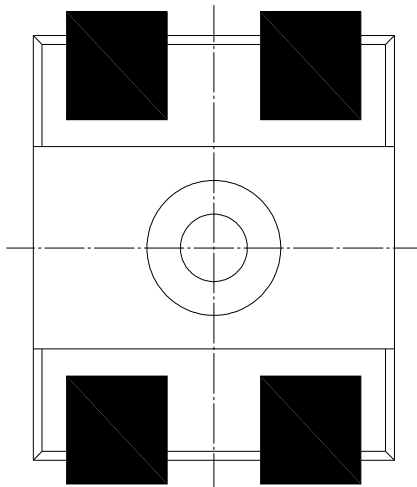
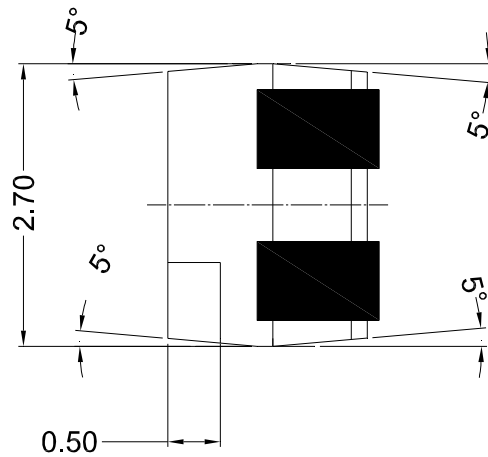
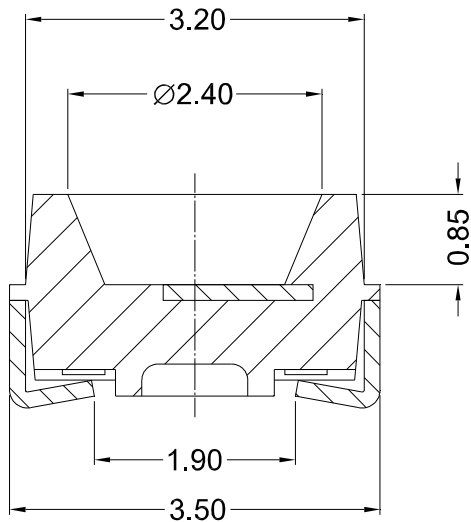
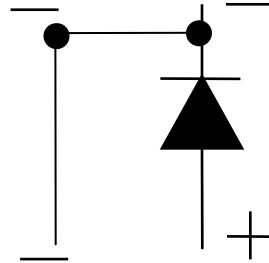
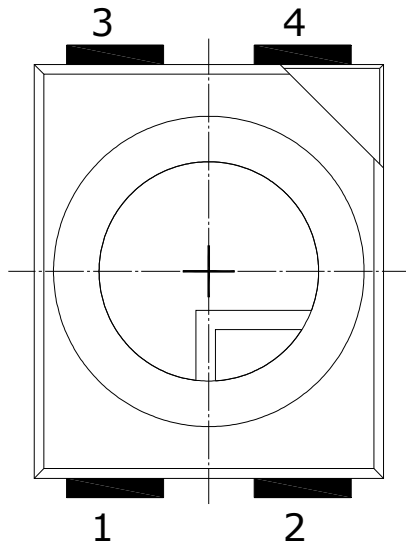

1. All dimensions are in millimeters.
2. Tolerances are ± 0.1 mm, unless otherwise noted.

Taping Dimension (unit= mm)

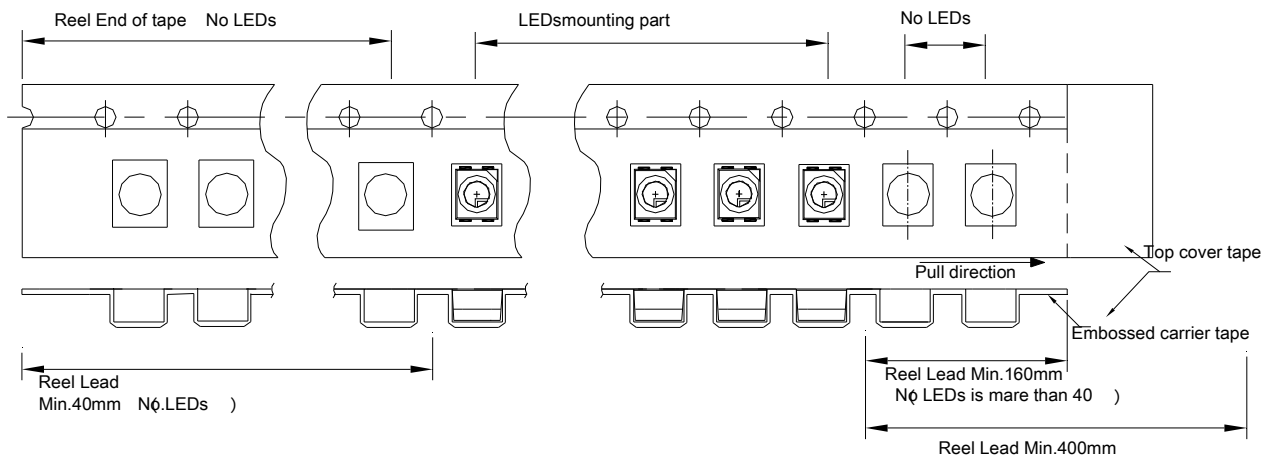
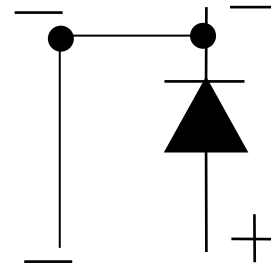
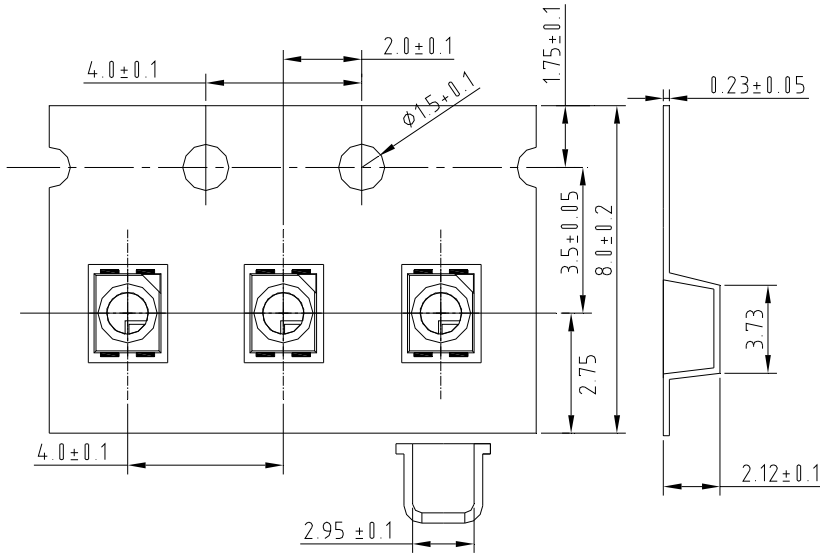
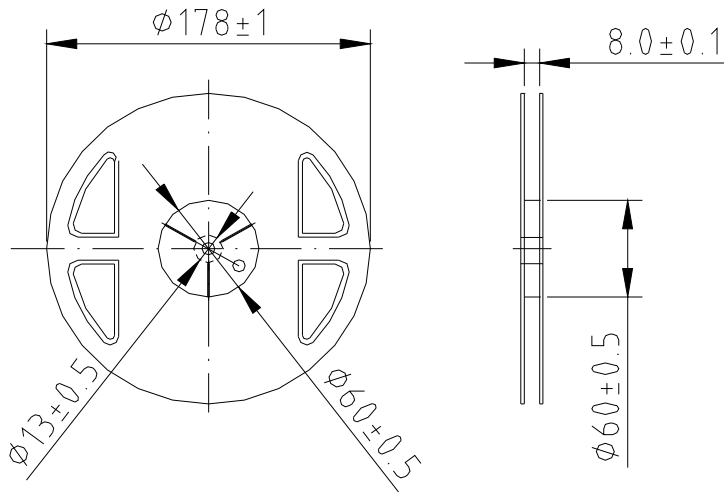

Tolerance: ± 0.2 (unit= mm)

Quantity: 2000 pcs/Reel

3. Handling Precaution

Recommended soldering conditions

1.1 Reflow solder temperature profile

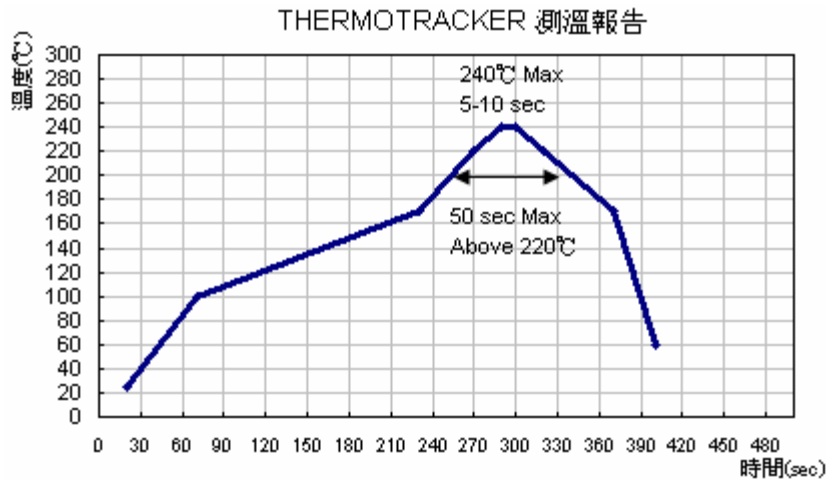

1.2 Recommended Soldering pad design (unit= mm)

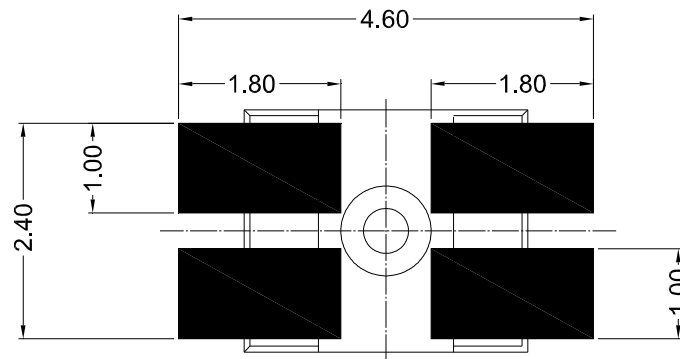

1.3 Soldering conditions

- Reflow soldering should not be done more than twice.
- When soldering, do not stress on LEDs during heating.
- After soldering, do not warp the circuit board.

Repairing

- Repair should not be done after the LEDs have been soldered. When repair is unavoidable, double-head soldering iron should be used. It should be confirmed beforehand whether the characteristics of the LEDs will be damaged by repair or not.

Cleaning

- It is recommended to use isopropyl alcohol as a solvent to clean the LEDs. When using other solvents, it should be confirmed beforehand whether the solvents will dissolve the package and the resin or not.

Advice on Device Usage

- It is recommended that user should complete the use of the whole package within 8 hours upon unsealing. In the event of incomplete usage, it is advised that user preheat the remaining devices at 60°C for 8 hours prior to use.